

Put Your Foamboard To Work

Tim Dykstra, CPF

Artists have canvas, plumbers have PVC, carpenters have plywood, and picture framers have foamboard. Thick or thin, rough or smooth, this universal product has changed picture framing for the better and has expanded our capabilities as framers. Few products have come our way that have had the impact on our industry that foamboard products have. It has given us a light-weight “backbone,” as well as unique preservation uses.

I entered into framing about the time foamboard took its place alongside mat board in the frame shop, pushing out cardboard and pressboard backings. Overnight, we became dependent upon the features of foamboard for mounting and backing. The age of foam had arrived.

Foamboard got its start as a backing and was soon found to be a great substrate for mounting posters and photographic work, with its smooth surface and inexpensive price tag. It was a good choice for framers who were used to cardboard backings and mat board substrates. Foamboard quickly simplified and upgraded backing and mounting in a non-preservation framing package.

Since then, a lot has changed. Preservation-quality surface papers are available; and although there is no evidence of the long-term stability of polystyrene, there is little to suggest that it cannot be used in preservation framing. Some are even packed with active zeolite protection against pollutants and off-gassing. The product is now safer and has added value built in, giving us exactly what we need for preservation framing.

Today with value added preservation foamboards that are perfect for archival framing, we have the tools to create unique looks in custom work. Your shop is probably like mine with stakes of long narrow strips of archival foamboard around. We all hate to throw away anything that could generate a dollar or two, so we need to create a use for this ‘scrap.’ Here are a few of my favorite uses for leftover foamboard.

Foamboard Spacers

How do you create depth to a flat piece of artwork in a framing package? Spacers! As Diagram 1 shows, by simply

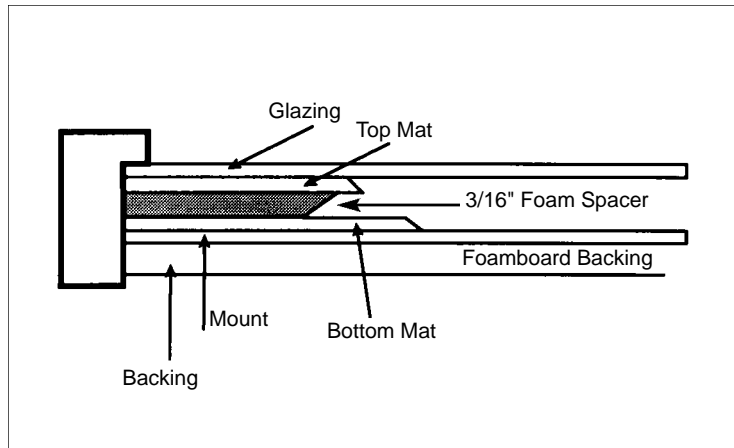

Diagram 1: Foamboard Used As A Mat Spacer

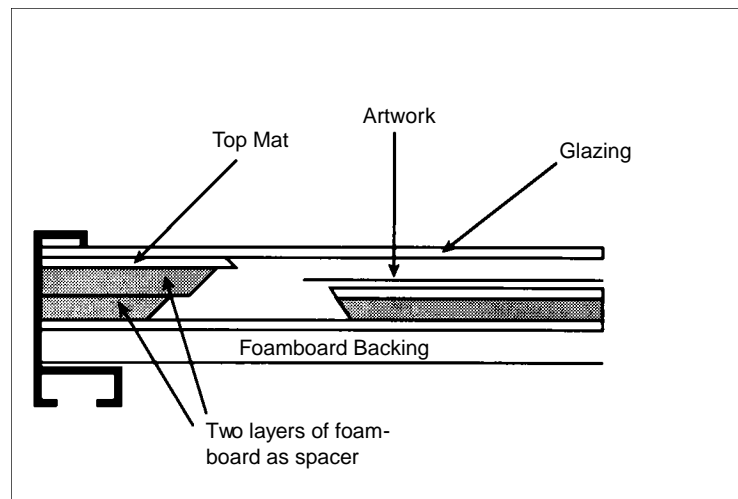

Diagram 2: Floated Artwork

Put Your Foamboard To Work

adding a $\frac{1}{8}$ " or $\frac{3}{16}$ " strip of preservation foamboard in between the top and the inner mats, it gives a touch of framing magic: a floated mat, a sense of depth. I suggest beveling the inner part of the foamboard to hide its presence even more; you still get the total effect, yet have the support to the mat board you need. This little trick is also great if an object is placed in the matting. This allows for the depth that is needed to keep the glass off everything inside the frame.

Floated Artwork

When a design calls for all the edges of a piece of artwork to show, as in a float mount presentation, it is best to mount the artwork first on a preservation mountboard. This by itself can look fine, but to dramatize the float even more, a preservation spacer can be added. Again, reverse back the bevels around the edges (see Diagram 2) and add it as a backing to the mounted artwork. Most of the time you will either build up the glass with spacer, or build up the mat borders as described earlier, with strips of archival foamboard just high enough to clear the floated artwork.

Deep Shadow Box Supports

When it comes to shadow boxes, more times than not, one to three layers of foam spacer won't be enough to gain the depth needed for objects inside. So you need to do some creative dimensioning. Cut your mat as you normally would and add strips of acid-free foamboard under every side securing it well with ATG tape.

Next, determine how deep you will need to go in order to clear the objects and still have room to keep the glass off everything. Now cut archival foamboard to that depth without bevels, just straight cuts. Next, add a preservation mat board to the visible parts, to finish off the inside look. Now using super stick ATG, attach these strips to the underside of your mat board foamboard package (see Diagram 3).

The technique is basically the same design as in building a bridge—the farther you span, the more supports you will need. Therefore, add as you need or add cross supports for even more strength. This gives depth and support without adding three inches of solid foam.

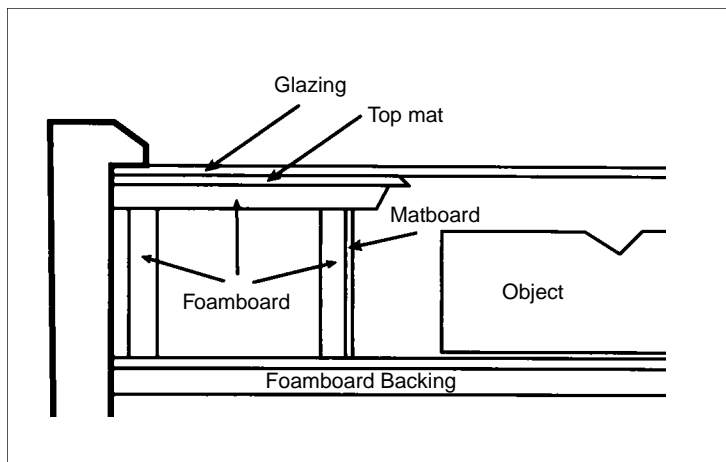

Diagram 3: Shadow Box Supports

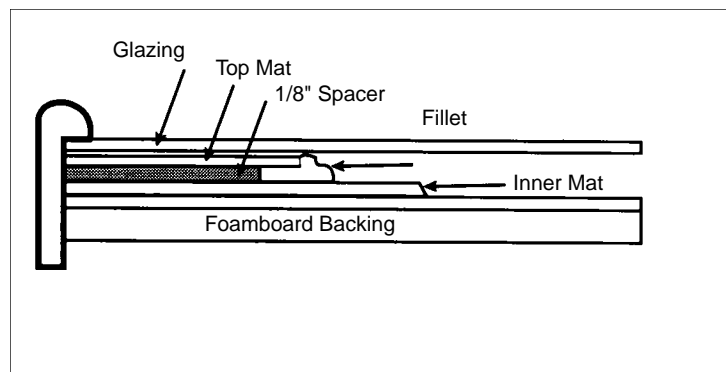

Diagram 4: Filler Spacer Board

Foamboard

Filler for Fillets

Placing a fillet in a mat board has become common place these days, but the problems with a good fitting fillet are still with us. You can still cut the perfect fillet and not have it lay flat and stay properly if you don't give it equal support. That is where $\frac{1}{8}$ " or $\frac{3}{16}$ " archival foam comes in.

Do your project as you normally would when it comes to "filling in the space." Space left between the fillet and the frame determines its thickness. More times than not, it will be equal to either of the board thicknesses that are available. Cut strips the size needed to fill in with a straight cut and use ATG to keep in place, pushing in tight at the corners of the fillet as you go. You will end up with a clean, tight, and evenly filled package. It will be ready to seal and place on your bottom mat (see Diagram 4).

Foamboard is a great time saver and it is always helpful to use up scrap. Settled in the background of a framing package you will find some sort of foamboard product. As a backing, substrate, spacer, or filler, it's perfect for the job at hand. Cut rings of foam to fit a plate into a ready-made plate frame more easily or formcut foam into a box when object framing. You can also take strips of it and cover the beveled edges with fabric or deco paper for a creative beveled inner mat.

And don't forget to use foamboard on promotional signs around the showroom. Black foamboard is perfect for signs and banner as well as standing price cards. Be creative and enjoy the endless possibilities with the foamboard. ■