

Preservation Practices



by Hugh Phibbs

Evolved Edge Strips

Techniques for supporting a work of art on paper by its edges have not been in use as long as support methods that rely on adhesives. Since all aspects of preservation must be open to continual evaluation and possible improvement, edge support strategies, too, should evolve.

Folded paper strips used for such support can be made of very thin paper; this will avoid undue pressure on the supported sheet when it is stored in a box. The use of thin paper also allows the strips to flex when conditions dictate that this is useful; special designs allow even thin paper to give rigid support when necessary. Such strips can be made longer than the edges of the item they support so that the excess portion at each corner will ensure that the supported sheet is not unduly confined. This latter proposition is true because the paper of the strips will expand when relative humidity rises (accommodating the expansion of the sheet), and the paper in the strips will contract when the relative humidity drops and the sheet shrinks.

These techniques can be refined to address another physical aspect of most papers: grain direction. Most papers and vir-

tually all machine-made papers have their fibers aligned—running in one direction. This alignment occurs during the manufacture of the sheet, either when the slurry of water and fibers is manipulated on the screen by the paper-

*As we refine
our thinking
about preservation
techniques, we must
continually re-evaluate
what we have done and
look for ways to improve
our techniques.*

maker, or when it is deposited on the support structures of the machine that is making it. In machine-made paper, the grain of the sheet will be parallel to the direction of manufacture. In handmade

papers, the grain tends to run parallel to the chain lines, impressions which are left in the sheet by the larger support wires in the screen.

In either case, the fibers will swell apart from one another as the relative humidity to which the sheet is conditioned rises. The result is that the sheet will expand across its grain direction much more than it will expand down its grain direction.

Finding the direction in which the grain of a sheet of paper runs is not a simple thing to do in many cases. When the sheet is thin and handmade, one can hold it up to the light and look for chain lines. Yet thicker sheets may not be transparent, and machine-made papers will not have true chain lines in them. Those who are well-schooled in the history and physics of paper can gently flex the sheet across its length and width and feel the greater resistance that the grain imparts. However, documents and works of art on paper should not be flexed, since the media used on their surface may be disturbed by the flexing. Therefore, ensuring that the edge support strips can accommodate

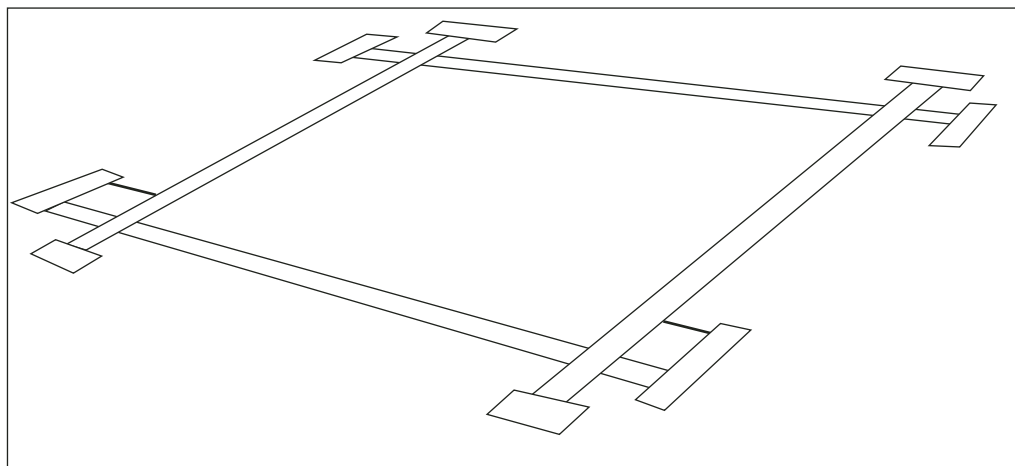

Figure 1: The edge strips should be secured to the back mat with water-activated linen tape at their ends, with space left between the tape site and the corner of the sheet.

expansion of the sheet will have to be accomplished without certain knowledge of the direction of the grain.

Creating the Edge Strips

The primary tool here is the use of strips of paper folded down their length, which are placed around the edges of the sheet. The paper used to make the edge strips should be acid-neutral, interleaving tissue paper or Japanese tissue paper. The strips are secured to the back mat with water-activated linen tape at their ends, with space left between the tape site and the corner of the sheet (see Figure 1). The strips should be pulled snug to give steady support, especially along the bottom edge. Water-activated linen tape is needed, since pressure-sensitive tape does not hold against pressure over time.

There can be further refinements made to the design of support strips that will accommodate the growth or contraction of the sheet being supported. The bottom strip has the greatest need for rigidity, since it will carry the weight of the paper being supported. The side and top strips are not likely to be required to carry any significant load, unless the frame is mishandled or improperly oriented. These can be designed to be more yielding than the bottom strip and, thus, they can provide the room needed for the expansion of the sheet in times of elevated relative humidity. The top and side strips can be made of lighter paper and can be made more narrow than the bottom strip—and both of these changes will make them more flexible. The flexibility of those strips will allow the sheet to expand out to the sides or up from the bottom, so the direction of the grain will not be a problem. If the grain runs horizontally, the sheet will expand up, because the bottom strip must be rigid and it will stop expansion

In creating edge strip supports, the use of thin paper allows the strips to flex when conditions dictate that this is useful; special designs allow even thin paper to give rigid support when necessary.

downward.

The bottom support can be made of an extra wide strip of paper which has been folded close enough to one of its sides so that the shorter side will cover enough of the front of the sheet to support it, but not so much that it can't be hidden by the covering portion of the window mat. The broad portion of the support will make it much more rigid, just as the thickness of a joist or I-beam gives strength enough to carry considerable weight.

Another option for making a strong bottom support strip is the twice-folded strip. This type is created from wider than normal strips of paper that are folded double, down their length. (A normal width for an edge strip paper is $\frac{3}{8}$ " to $\frac{3}{4}$ "; a wider than normal would be $\frac{3}{4}$ " to $1\frac{1}{4}$ ".) They are then folded again down their length, close to the first fold, and then opened so that a

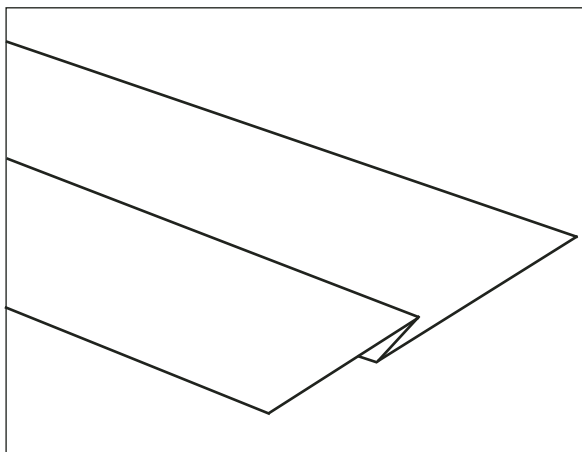

Figure 2: The twice-folded edge strip can be used to create a strong support along the bottom of the work of art on paper.

small trough remains down the center of the strip (see Figure 2). The use of this type of strip raises the issue of thickness, since the extra fold makes this twice as thick as it would ordinarily be.

Matted items are generally situated in a frame, storage box, or drawer. Long-term storage in a frame represents many physical challenges for a sheet of paper. It is exposed to light, possibly to dampness (through proximity to damp walls), and

the stress of long-term exposure to gravity. The one thing that vertical orientation mitigates is the possibility of excess pressure between the window and the back mat. Even if there is excessive humidity behind the frame and the backing board warps inward toward the glazing, it is likely to press on the center of the matted sheet rather than the edges of the window.

However, a matted work may at some time be

stored in a box, and if it is in a stack of matted items, there is a greater likelihood that there will be more pressure between the edges of the window and the surface of the sheet. When a thicker edge support strip is used at only one edge, a shim of two- or four-ply should be attached to the back of the window mat, along the edge that has the thicker support strip. This shim should be set beyond the margin of the supported sheet, as is the case when thicker edge strip supports are being used on all sides of the paper (see Figure 3). Putting the shim on the back of the window leaves that surface of the back mat free for application of the ends of the edge strip supports.

As we refine our thinking about preservation techniques, we must continually re-evaluate what we have done and look for ways to improve our techniques. Preservation is a race against time and our environment, which oxidizes, humidifies, desiccates, and erodes. New materials and methods will always be useful, since some materials on which we have depended may become unavailable, and new and more challenging items will need to be preserved. It is the constant drive to improve

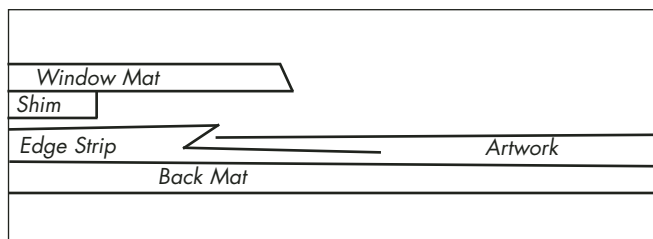

Figure 3: When a thicker edge support strip is used at only one edge, a shim of two- or four-ply should be attached to the back of the window mat, along the edge that has the thicker support strip. The ends of the edge strip is folded to be attached to the back mat with linen tape.

our work that ensures that preservation will do the best job possible in meeting new challenges. ■

Hugh Phibbs, Preservation Editor, is the coordinator of graphics conservation services in the Department of Exhibitions and Loans, Conservation Division, National Gallery of Art, Washington, D.C. He has taught workshops for the National Conference, the AIC, PPFA, the conservation programs at Winterthur/University of Delaware, and the Smithsonian Resident Associates Program. He also compiled the matting and framing section of “The Book and Paper Group Outline.”